

THIS DRAWING IS UNPUBLISHED. RELEASED FOR PUBLICATION
 © COPYRIGHT BY TYCO ELECTRONICS CORPORATION. ALL INTERNATIONAL RIGHTS RESERVED.

LOC	DIST	REVISIONS			
P	LTR	DESCRIPTION	DATE	DWN	APVD
	W	ECR-08-023872	17-10-08	AEG	KMA

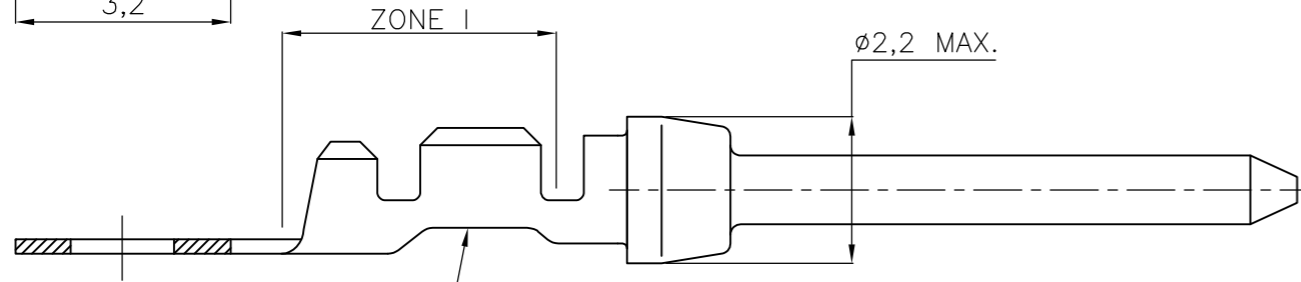
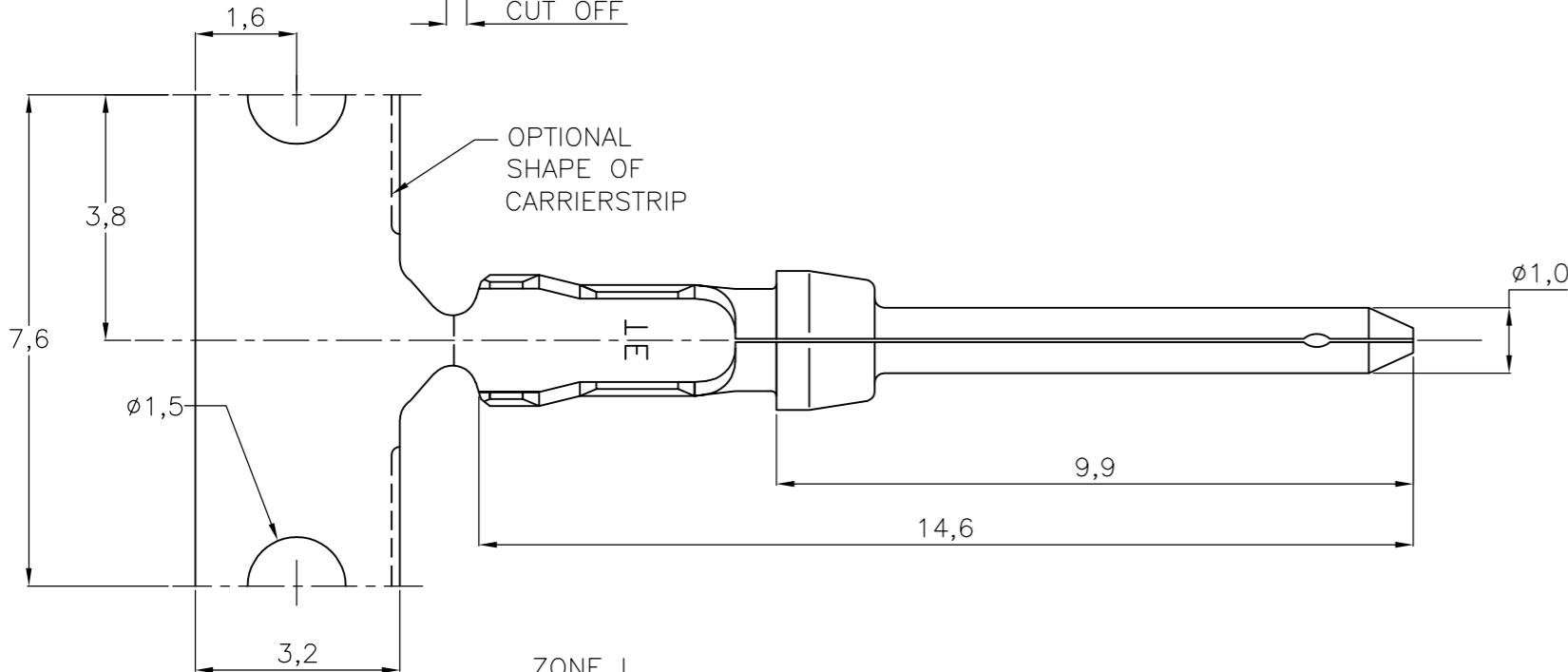
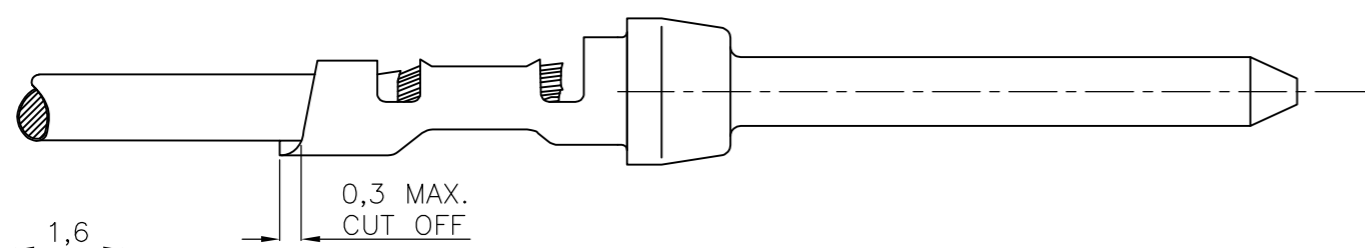
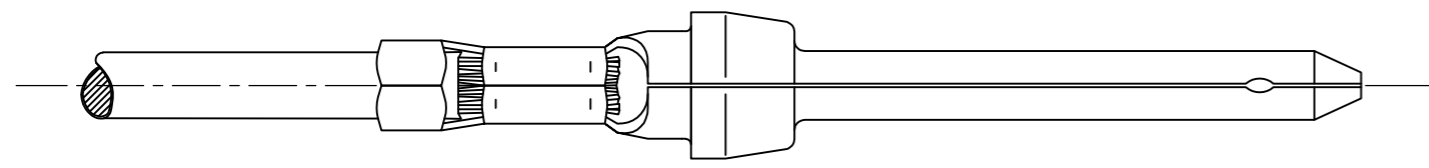

BLUE COLOR CODE
(LOOSE-PIECE ONLY)

- NOTES:
- △1 FOR MINI-APPLICATOR-12500 PCS REEL.
 - △2 FOR REEL-FEED HAND TOOLING-500 PCS REEL.
 - △3 FOR HAND TOOLING- LOOSE PIECE.
 - 4. MATERIAL: PHOSPHORBRONZE.
 - △5 FINISH:
 - Ni UNDERPLATING ALL OVER.
 - CONTACT AREA PLATING MEETS IEC-807-3 PERFORMANCE LEVEL 2.
 - CRIMP ZONE Sn PLATED.

WIRE RANGE: 24-28 AWG(0,08-0,22mm²)
 INSUL. RANGE: 0,76 - 1,02 mm DIA.

△5	166294-1	5-166054-1	166054-1
FINISH	LOOSE PIECE △3	PART NUMBER △2	PART NUMBER △1
DWN	-	Tyco Electronics Corporation 's-Hertogenbosch, Nederland	
CHK	K. MALCZYK 09SEP08	NAME	
APVD	T. DE BOER 09SEP08	PIN CONTACT, SIZE 20 DF.	
PRODUCT SPEC	108-40005	SIZE	RESTRICTED TO
APPLICATION SPEC	114-10000	CAGE CODE	
WEIGHT	-	DRAWING NO	
CUSTOMER DRAWING		A3 00779	166054
SCALE		NTS	SHEET 1 OF 1
		REV	W

THIS DRAWING IS A CONTROLLED DOCUMENT.

DIMENSIONS:	TOLERANCES UNLESS OTHERWISE SPECIFIED:
mm	
	0 PLC ± -
	1 PLC ± 0,127
	2 PLC ± -
	3 PLC ± -
	4 PLC ± -
	ANGLES ± ± -
MATERIAL	FINISH
-	-